



SOLUCIONES NAVALES S.R.L



WINDOWS AND SIDE-SCUTTLES
VENTANAS Y OJOS DE BUEY
JANELAS E VIGIAS



CERTIFIED
PRODUCTS

OPENING WINDOW WOT

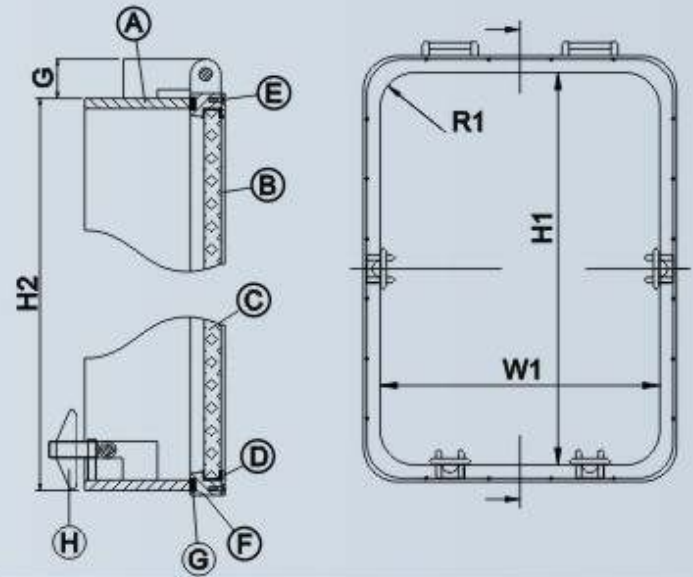

OPENING WINDOW WIT

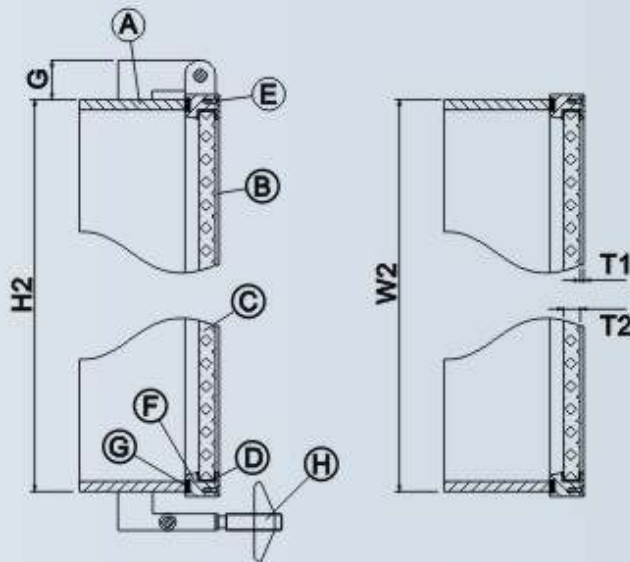

Position	Description	Materials
A	Welding frame	Steel - Stainless Steel
B	Screwing list	Brass - Alluminium
C	Glass Pane	Toughened glass
D	Rubber U-Profile	EPDM
E	Screws	Brass - Stainless Steel
F	Main Frame	Brass - Alluminium
G	Rubber Gasket	EPDM
H	Fasteners	Brass

Type	Nominal Size		Frame Size		R1	C min	G max	T1	T2	
	W1	H1	W2	H2					L	H
1	300	425	348	473	50	30	41	3	8	10
2	355	500	403	548	50	30	41	3	8	10
3	400	560	448	608	50	30	41	3	8	12
4	450	630	498	678	100	30	41	3	8	12
5	500	710	548	758	100	30	41	3	10	15
6	560	800	608	848	100	30	41	3	10	15
7	900	630	948	678	100	30	41	3	12	19
8	1000	710	1048	758	100	30	41	3	12	19
9	1100	800	1148	848	100	30	41	3	15	-

Dimensions in mm

NOMENCLATURE	T	Top opening or top- hinged	Apertura hacia arriba	Abertura para acima
	(L/R)	Left/right opening or side-hinged	Apertura lateral	Abertura lateral
	I	Inwards opening	Abrible hacia adentro	Abrible para adentro
	O	Outwards opening	Abrible hacia fuera	Abrible para afora
	F	Fixed or non opening	Fijo/a	Fixo/a
	(W/D)	With deadlight/cover	Con tapa	Com tampa
	(WO/D)	Without deadlight/cover	Sin tapa	Sem tampa
W	Welded	De soldar	De soldar	

Also available in other sizes upon client requirement

Disponibles en otras medidas a requerimiento del cliente

Disponível em outras medidas a requerimento do cliente



OPENING WINDOW WO (L/R)

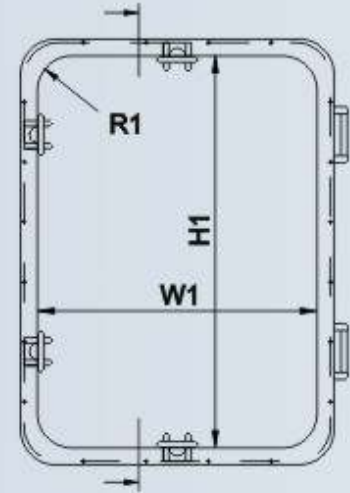
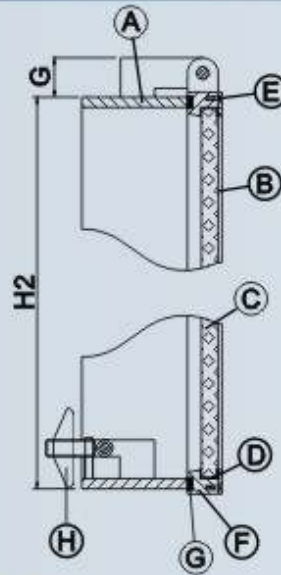

OPENING WINDOW WI (L/R)

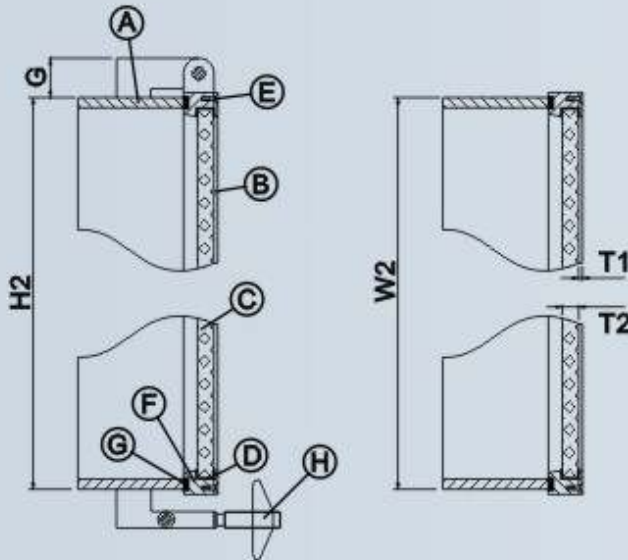

Position	Description	Materials
A	Welding frame	Steel - Stainless Steel
B	Screwinglist	Brass - Alluminium
C	Glass Pane	Toughened glass
D	Rubber U-Profile	EPDM
E	Screws	Brass - Stainless Steel
F	Main Frame	Brass - Alluminium
G	Rubber Gasket	EPDM
H	Fasteners	Brass

Type	Nominal Size		Frame Size		R1	C min	G max	T1	T2	
	W1	H1	W2	H2					L	H
1	300	425	348	473	50	30	41	3	8	10
2	355	500	403	548	50	30	41	3	8	10
3	400	560	448	608	50	30	41	3	8	12
4	450	630	498	678	100	30	41	3	8	12
5	500	710	548	758	100	30	41	3	10	15
6	560	800	608	848	100	30	41	3	10	15
7	900	630	948	678	100	30	41	3	12	19
8	1000	710	1048	758	100	30	41	3	12	19
9	1100	800	1148	848	100	30	41	3	15	-

Dimensions in mm

NOMENCLATURE	T	Top opening or top- hinged	Apertura hacia arriba	Abertura para acima
	(L/R)	Left/right opening or side-hinged	Apertura lateral	Abertura lateral
	I	Inwards opening	Abrible hacia adentro	Abrible para adentro
	O	Outwards opening	Abrible hacia fuera	Abrible para afora
	F	Fixed or non opening	Fijo/a	Fixo/a
	(W/D)	With deadlight/cover	Con tapa	Com tampa
	(WO/D)	Without deadlight/cover	Sin tapa	Sem tampa
W	Welded	De soldar	De soldar	

Also available in other sizes upon client requirement

Disponibles en otras medidas a requerimiento del cliente

Disponível em outras medidas a requerimento do cliente

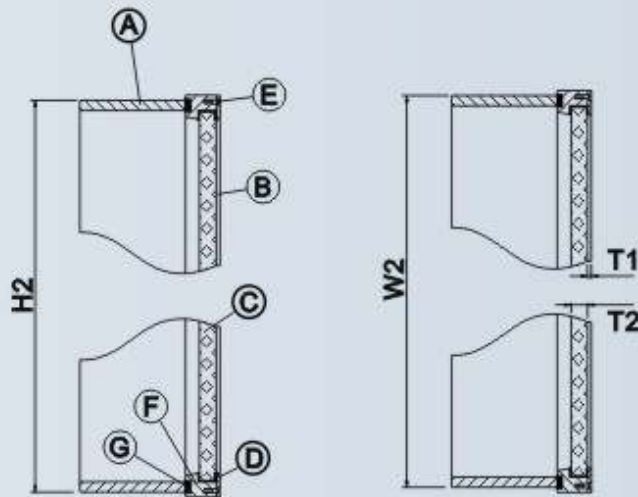
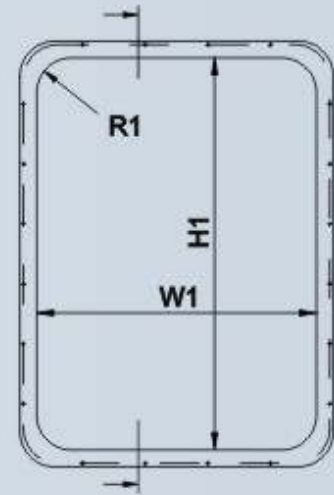

Position	Description	Materials
A	Welding frame	Steel - Stainless Steel
B	Screwinglist	Brass - Alluminium
C	Glass Pane	Toughened glass
D	Rubber U-Profile	EPDM
E	Screws	Brass - Stainless Steel
F	Main Frame	Brass - Alluminium
G	Rubber Gasket	EPDM
H	Fasteners	Brass

Type	Nominal Size		Frame Size		R1	C min	G max	T1	T2	
	W1	H1	W2	H2					L	H
1	300	425	348	473	50	30	41	3	8	10
2	355	500	403	548	50	30	41	3	8	10
3	400	560	448	608	50	30	41	3	8	12
4	450	630	498	678	100	30	41	3	8	12
5	500	710	548	758	100	30	41	3	10	15
6	560	800	608	848	100	30	41	3	10	15
7	900	630	948	678	100	30	41	3	12	19
8	1000	710	1048	758	100	30	41	3	12	19
9	1100	800	1148	848	100	30	41	3	15	-

Dimensions in mm

NOMENCLATURE	T	Top opening or top- hinged	Apertura hacia arriba	Abertura para acima
	(L/R)	Left/right opening or side-hinged	Apertura lateral	Abertura lateral
	I	Inwards opening	Abrible hacia adentro	Abrible para adentro
	O	Outwards opening	Abrible hacia fuera	Abrible para afora
	F	Fixed or non opening	Fijo/a	Fixo/a
	(W/D)	With deadlight/cover	Con tapa	Com tampa
	(WO/D)	Without deadlight/cover	Sin tapa	Sem tampa
W	Welded	De soldar	De soldar	

Also available in other sizes upon client requirement

Disponibles en otras medidas a requerimiento del cliente

Disponível em outras medidas a requerimento do cliente

OPENING SIDE-SCUTTLES W(W/D)

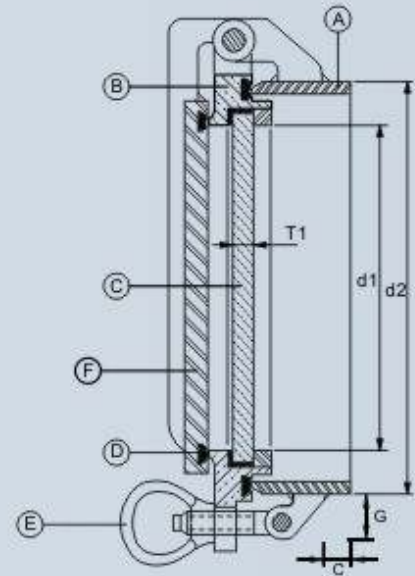

OPENING SIDE-SCUTTLES W(WO/D)

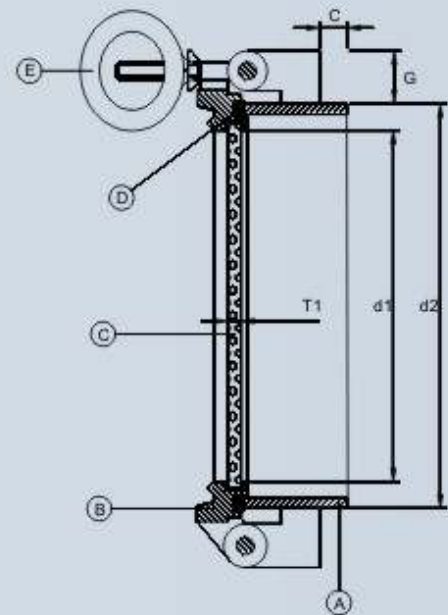

Position	Description	Materials
A	Welding frame	Steel - Stainless Steel
B	Main Frame	Brass - Alluminium
C	Glass Pane	Toughened glass
D	Rubber Gasket	EPDM
E	Fasteners	Brass
F	Deadlight	Steel

Type	Nominal Size d1	Frame Size d2	G	C	T1 Glass Thickness		
					Type A	Type B	Type C
1	450	510	45	30	X	X	10
2	400	460	45	30	19	12	10
3	350	410	45	30	15	12	8
4	300	360	45	30	15	10	8
5	250	305	47,5	30	12	8	6

Dimensions in mm

NOMENCLATURE	T	Top opening or top- hinged	Apertura hacia arriba	Abertura para acima
	(L/R)	Left/right opening or side-hinged	Apertura lateral	Abertura lateral
	I	Inwards opening	Abrible hacia adentro	Abrible para adentro
	O	Outwards opening	Abrible hacia fuera	Abrible para afora
	F	Fixed or non opening	Fijo/a	Fixo/a
	(W/D)	With deadlight/cover	Con tapa	Com tampa
	(WO/D)	Without deadlight/cover	Sin tapa	Sem tampa
	W	Welded	De soldar	De soldar

Also available in other sizes upon client requirement

Disponibles en otras medidas a requerimiento del cliente

Disponível em outras medidas a requerimento do cliente



SIDE-SCUTTLES WF(W/D)

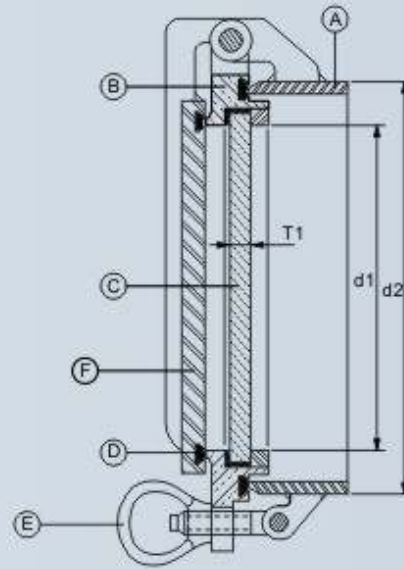

SIDE-SCUTTLES WF(WO/D)

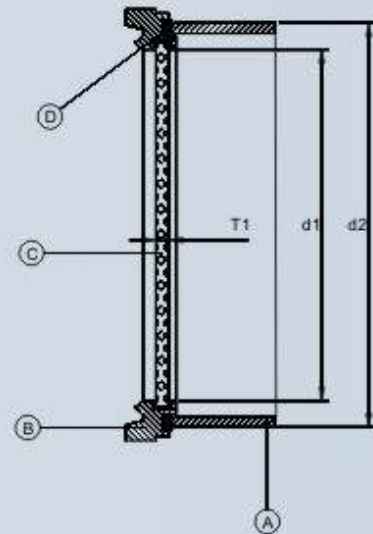

Position	Description	Materials
A	Welding frame	Steel - Stainless Steel
B	Main Frame	Brass - Alluminium
C	Glass Pane	Toughened glass
D	Rubber Gasket	EPDM
E	Fasteners	Brass
F	Deadlight	Steel

Type	Nominal Size	Frame Size	G	C	T1 Glass Thickness		
	d1	d2			Type A	Type B	Type C
1	450	510	45	30	X	X	10
2	400	460	45	30	19	12	10
3	350	410	45	30	15	12	8
4	300	360	45	30	15	10	8
5	250	305	47,5	30	12	8	6

Dimensions in mm

NOMENCLATURE	T	Top opening or top- hinged	Apertura hacia arriba	Abertura para acima
	(L/R)	Left/right opening or side-hinged	Apertura lateral	Abertura lateral
	I	Inwards opening	Abrible hacia adentro	Abrible para adentro
	O	Outwards opening	Abrible hacia fuera	Abrible para afora
	F	Fixed or non opening	Fijo/a	Fixo/a
	(W/D)	With deadlight/cover	Con tapa	Com tampa
	(WO/D)	Without deadlight/cover	Sin tapa	Sem tampa
	W	Welded	De soldar	De soldar

Also available in other sizes upon client requirement

Disponibles en otras medidas a requerimiento del cliente

Disponível em outras medidas a requerimento do cliente

CLEAR VIEW SCREEN

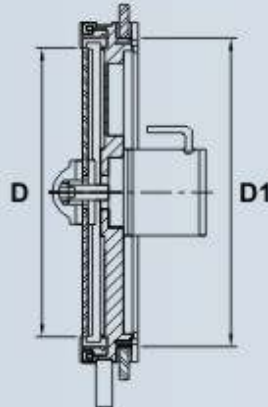

DIM	(unit : mm)
Nominal Size-D	Glass Cutting Size-D1
250	276
300	326
350	382

Frame Material	Al.-alloy
Motor Output	60W, 80W
Power	AC 110 - 220 V DC 12 - 24 V
R.P.M.	1900 ± 200

Application: Fixed windows in front of a wheel house
Particularity: Secure field of vision in case of rain and snow

WINDOW WIPER PANTOGRAPH TYPE



	Constant	2 - Speed	Variable
Stroke(max)	1800	1800	1800
Arm(max)	1000	1000	1000
Blade(max)	1000	1000	1000
Speed	35 cycle/min	Low 35 cycle/min high 55 cycle/min	
Voltage	AC 110V/220V, 1/3, 50/60		
Weight	Abt. 7kg	Abt. 7kg	Abt. 7kg

Application: Fixed windows in front of a wheel house
Particularity: Moving a blade in a fanwise motion to remove rainwater

WINDOW WIPER STRAIGHT TYPE

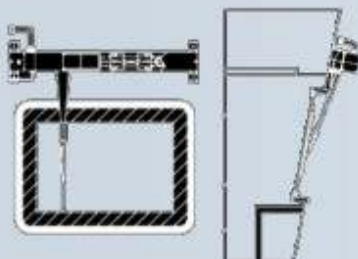

	Constant	2 - Speed	Variable
Stroke(max)	1800/2100	1800/2100	1800/2100
Arm(max)	1000	1000	1000
Blade(max)	1000	1000	1000
Speed	32 cycle/min	Low 22 cycle/min high 32 cycle/min	16 5 32 5 cycle/min
Voltage	AC 110V/220V, 1/3, 50Hz/60Hz		
Weight	Abt. 20kg	Abt. 20kg/25 Kg	Abt. 20kg/25 Kg

Application: Fixed windows in front of a wheel house
Particularity: Moving a blade in a parallel motion to remove rainwater



3595 Solis st. - (7600) MardelPlata city, Buenos Aires, Argentina
Phone/Fax: 54 223 480 6766 - ID Nextel: 54*128*4832/54*128*7872
www.lapasteca.com.ar - info@lapasteca.com.ar - msn:lapasteca@hotmail.com